

energy of the positive kernels. This principle is applied in a number of cases, with the following results.

It is shown, in agreement with chemical evidence, that the structures of carbon dioxide and nitrous oxide are OCO and NNO rather than COO and NON.

The greater stability of the cyanate ion, NCO^- , as compared with the fulminate ion, CNO^- , is explained.

It is shown that theoretically the isocyanates, RNCO , should be more stable than the cyanates, ROCN . Furthermore, the postulate leads to the conclusion that fulminic acid and the inorganic fulminates have the formulas HCNO and MCNO , rather than the accepted ones HONC and MONC . Moreover, the nitrile oxides are considered to be esters of fulminic acid, and to have the formula RCNO , rather than $\text{R.C}=\text{N}$.



All of the suggested structures are shown to be compatible with the experimental evidence.

The principle explains the observation that the nitriles, RCN , are more stable than the isocyanides, RNC . The structures HCN for hydrocyanic acid, $(\text{M}^+)(\text{CN}^-)$ for the cyanides of the alkali metals, and MCN for those of the heavy metals are shown to be in agreement with their chemical properties.

The accepted formula NCCN for cyanogen is shown to be the predicted one. The accepted formula CNX for the cyanogen halides is, however, rejected in favor of the predicted formula NCX .

PASADENA, CALIFORNIA

[CONTRIBUTION FROM THE LABORATORY OF PHYSICAL CHEMISTRY OF THE
GEORGE WASHINGTON UNIVERSITY]

CRYSTAL ANGLES, MEASURED UNDER THE MICROSCOPE

By EDWIN A. HILL

RECEIVED NOVEMBER 16, 1925

PUBLISHED MARCH 5, 1926

For several years the writer in the courses in Chemical Microscopy given by him at the George Washington University, in which the "Elementary Chemical Microscopy" of Professor Chamot is used as a textbook, has given to his students a simple method whereby all of the solid angles in any crystal, however microscopically small, when found upon the object slide can be readily measured, with considerable accuracy, without removing the crystal from the slide upon which it has been formed, or without the use of any special piece of apparatus, a measurement which, so far as I am aware, could not hitherto be made, in cases where the crystal is too small, or too firmly attached, to be removed from the object slide and mounted in a goniometer.

It is believed that this method will be useful to those engaged in this branch of microscopical research, and I will now describe it in detail.

Let the figure represent a vertical section through the optic axis AA' of the microscope (O being its objective), taken when a crystal is positioned for observation in the center of the field of view, GG' being the upper surface of the glass object slide on which the crystal is resting. Also, let the crystal planes, represented in section, respectively, by EE', E'E'', E''E''', etc., lie so that the intersecting edges E', E'' and E''' between these planes, will be perpendicular to the plane of the paper, and parallel to one another.

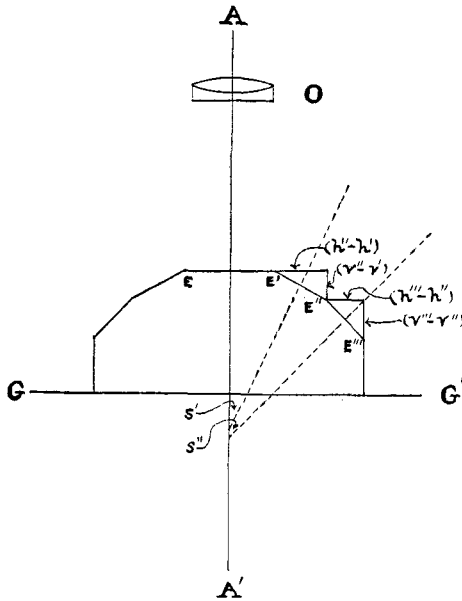

The instrument is then carefully focused upon the edge E', there being a micrometer measuring disk in the eye piece. The position of the edge E' upon the eye piece micrometer scale is then recorded in microns as h' , and the reading of the divisions of the micrometer screw of the fine adjustment is recorded in microns as v' , h' and v' , being termed the respective horizontal and vertical coordinates of the edge E'.

For the edges E'' and E''' are successively measured and recorded, in like manner in microns, the corresponding coordinates h'' and v'' , and h''' and v''' , after successively sharply focusing upon the edges E'' and E'''.

Now by trigonometry it can easily be proved that for any edges E', E'', E''', etc., we have the following equations

$$\text{Tan. } S' = \frac{v'' - v'}{h'' - h'}; \text{ Tan. } S'' = \frac{v''' - v''}{h''' - h''}, \text{ etc.} \tag{1}$$

where S' , S'' , etc., are the slope angles of the planes E'E'E'' and E''E''E''', respectively; that is, the angle, made by the normals of these planes in intersecting the optical axis AA' of the microscope.

For the angle e'' between the normals of two planes intersecting in an edge E'', which is parallel to the face of the microscope stage we have the relation

$$e'' = S'' - S' \tag{2}$$

e'' being the angle usually measured with the goniometer in mathematical crystallography.

After computing the values of Tan. S' , Tan. S'' , etc., by Formula 1, the

values of the slope angles S' , S'' , etc., of the crystal planes $E' E''$, $E'' E'''$, etc., can readily be obtained by inspection from a table of natural tangents, and the values of e' , e'' , etc., the angles measured between intersecting planes, can be obtained by using Formula 2.

The horizontal coördinates, h' , h'' , etc., can also be obtained in microns in any other way desired.¹

It is well understood in making horizontal measurements with the compound microscope, that when the illumination is not truly central a slight raising or lowering of the microscope tube will cause an apparent shifting of the object to the left or right, or forward or backward, or a combination of both of these motions; and evidently when such inaccurate illumination is present and disregarded, this apparent lateral shifting of the edge under examination may introduce serious errors in the values found for the horizontal components, h' , h'' , h''' , etc.

Slight but carefully-made adjustments of the mirror of the instrument entirely remove this cause of inaccuracy, and the mirror should, therefore, be adjusted and readjusted until, on slightly raising and lowering the body tube, no lateral shifting of the image can be observed in any direction.² The presence of sloping faces on the bottom of the crystal may interfere, however, with the attempt to secure true central illumination.

It is also apparent that the smaller the vertical movement of the body tube required to throw the edge being observed out of focus, the more accurate will be the values obtained for the vertical coördinates v' , v'' , v''' , etc., which clearly points to the use of objectives having high power and small depth of focus.

In every case the fine adjustment screw should be turned backward and forward until the point of maximum sharpness of definition is obtained, at which point the value of the vertical coördinate v in microns should be taken from the fine adjustment screw, the final focusing always being made in the same direction to avoid errors due to back lash in the fine adjustment screw.

It is quite evident that the greater the depth of focus, which an objective possesses, the less definite will be the position of the micrometer screw of the fine adjustment, for the position of sharpest focus of a crystal edge; so that since depth of focus is in inverse relation to numerical aperture, as the numerical aperture and magnifying power of an objective increases, the accuracy of the measurement of the vertical coördinates v' , v'' , etc., will also increase or if a = accuracy of the measurement, N the numerical aperture, NA , of the objective and p its magnifying power, the expression

¹ See for such methods, Chamot, "Elementary Chemical Microscopy," John Wiley and Sons, New York, 1921, pp. 142 to 148.

² See also Ref. 1, p. 38; and Gage, "The Microscope," Ithaca, N. Y., 1908, p. 48, Ref. 1, p. 158.

$a = p^2N$ indicates the relative accuracy, all of which indicates the use for vertical measurements of as high a magnifying power and value of numerical aperture NA as possible if the errors in vertical measurements are to be made a minimum.³

In measuring an edge angle it should always be made certain that the edge in question is parallel to the face of the stage of the microscope and, therefore, perpendicular to the optic axis.

This parallelism of the observed edge can be proved by sharply focussing upon one end of the edge and then observing whether the other end of the edge is also equally sharp in focus.

If one end of the edge is higher than the other, the computed value of the edge angle due to this tilting of the edge will exceed its true value.

It should also be noted that measurements of the horizontal components, h' , h'' , etc., should be made in a direction perpendicular to the edge under examination and be made to some sharply defined point of reference on the plane whose slope angle is being determined. Such a point can be a point on the plane in question formed by the intersection of two other edges, or any point taken in another edge whether this second edge is parallel or not, the only matter of importance being that coördinate h must be measured perpendicularly to the horizontal edge of intersection and from that edge to some other point of reference in the given plane.

Moreover, if the slope angle S is to be determined from the vertical and horizontal coördinates v and h of two different points in the plane, those points must lie in a common plane which is perpendicular to the plane whose slope angle S is being determined.

Summary

A new method is described for the measurement, under the microscope, of solid crystal angles, and of the slope angles of crystal faces, by the use of the ordinary eye piece micrometer disks and the graduations of the fine adjustment screw.

WASHINGTON, D. C.

³ On depth of focus, see Chamot, Ref. 1, p. 7 and Spitta, "Microscopy," E. P. Dutton and Co., New York, 1920, pp. 99 to 103.